



# education

---

Department:  
Education  
**REPUBLIC OF SOUTH AFRICA**

**NATIONAL  
SENIOR CERTIFICATE**

**GRADE 12**

**PHYSICAL SCIENCES: CHEMISTRY (P2)**

**FEBRUARY/MARCH 2009**

**MARKS: 150**

**TIME: 3 hours**

**This question paper consists of 15 pages, 4 data sheets and an answer sheet.**

**INSTRUCTIONS AND INFORMATION**

1. Write your examination number (and centre number if applicable) in the appropriate spaces on the ANSWER BOOK and ANSWER SHEET.
2. Answer ALL the questions.
3. This question paper consists of TWO sections:  
  
SECTION A (35 marks)  
SECTION B (115 marks)
4. Answer SECTION A on the attached ANSWER SHEET.
5. Answer SECTION B in the ANSWER BOOK.
6. Non-programmable calculators may be used.
7. Appropriate mathematical instruments may be used.
8. Number the answers correctly according to the numbering system used in this question paper.
9. Data sheets are attached for your use.
10. Wherever motivations, discussions, et cetera are required, be brief.

**SECTION A**

Answer this section on the attached ANSWER SHEET.

**QUESTION 1: ONE-WORD ITEMS**

Give ONE word/term for each of the following descriptions. Write only the word/term next to the question number (1.1 – 1.5) on the attached ANSWER SHEET.

- 1.1 Atoms, groups of atoms or bonds that give a homologous series its characteristic properties (1)
- 1.2 A homologous series with the general formula  $RNH_2$  (1)
- 1.3 The minimum energy required to start a chemical reaction (1)
- 1.4 The type of electrochemical cell in which electrical energy is converted to chemical energy (1)
- 1.5 The gas that forms at the positive electrode of a membrane cell (1)
- [5]**

**QUESTION 2: MATCHING ITEMS**

Choose an item from COLUMN B that matches a description in COLUMN A. Write only the letter (A – J) next to the question number (2.1 – 2.5) on the attached ANSWER SHEET.

COLUMN A		COLUMN B	
2.1	A compound that is always present in alcoholic beverages	A	cathode
2.2	An arene	B	reaction rate
2.3	Change in concentration of reactants per unit time	C	$CH_3OH$
2.4	The electrode in an electrochemical cell where oxidation occurs	D	$Na^+$
2.5	The ions that migrate through the cell membrane of the membrane cell	E	$C_6H_{10}$
		F	chemical equilibrium
		G	$C_2H_5OH$
		H	$Cl^-$
		I	$C_6H_5(CH_3)$
		J	anode

**[5]**

**QUESTION 3: TRUE/FALSE ITEMS**

Indicate whether the following statements are TRUE or FALSE. Choose the answer and write 'true' or 'false' next to the question number (3.1 – 3.5) on the attached ANSWER SHEET. Correct the statement if it is FALSE.

3.1 Ketones contain a carbonyl group. (2)

3.2 Some catalysts can speed up a chemical reaction by providing a new, lower energy pathway. (2)

3.3 The equilibrium constant for an exothermic reaction decreases with increase in temperature. (2)

3.4 The standard conditions used to measure standard electrode potentials are:

- A temperature of 273 K
- A concentration of 1 mol·dm<sup>-3</sup>
- A pressure of 101,3 kPa (2)

3.5 A primary cell can be recharged. (2)

**[10]****QUESTION 4: MULTIPLE-CHOICE QUESTIONS**

Four options are provided as possible answers to the following questions. Each question has only ONE correct answer. Choose the answer and make a cross (X) in the block (A – D) next to the question number (4.1 – 4.5) on the attached ANSWER SHEET.

4.1 The condensed structural formula of an organic compound is shown below:

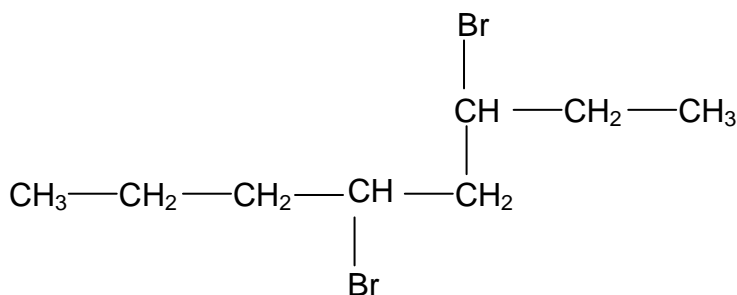

Which ONE of the following is the correct IUPAC name of this compound?

- A 4,6-dibromooctane
- B 4-bromo-5-bromo-5-propylpentane
- C 3,5-dibromooctane
- D 2-bromo-1-bromo-1-propylpentane (3)

4.2  $\text{N}_2\text{O}_4(\text{g})$  is placed in an evacuated, sealed container.

The following reaction takes place in the container at constant temperature:

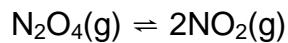

The concentration of the product is measured over time.

Which ONE of the following graphs correctly illustrates the relationship between the nitrogen dioxide ( $\text{NO}_2$ ) concentration and time?

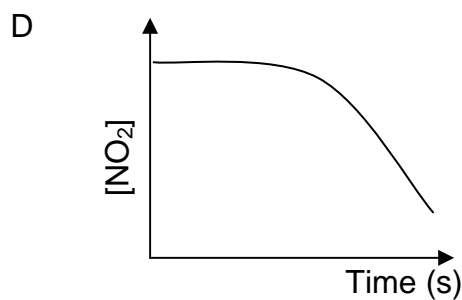
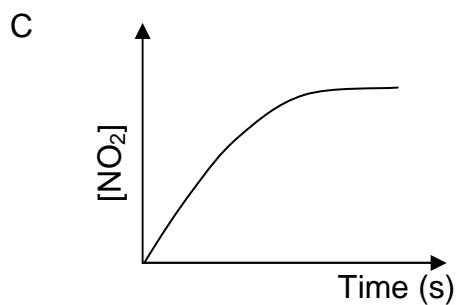
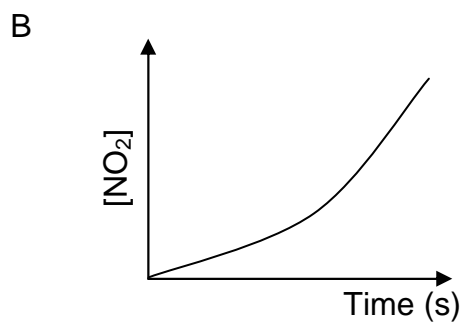
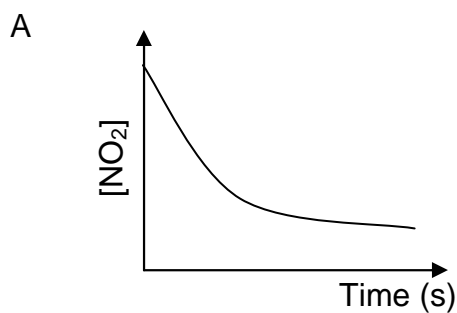

(3)

4.3 The following hypothetical reaction is at equilibrium at 300 K:

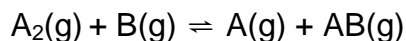

The diagram below shows the molecules involved in this chemical equilibrium at 300 K.

The white circles represent atoms of A and the black circles represent atoms of B.

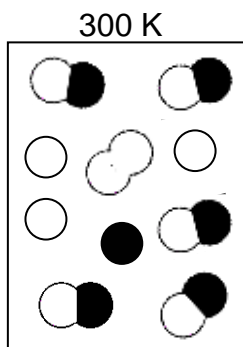

The temperature is increased to 500 K.

The diagram below represents the same equilibrium mixture at 500 K.

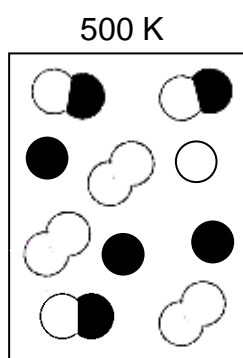

Which ONE of the following statements is CORRECT?

- A The forward reaction is exothermic.
- B The concentration of AB is lower at a lower temperature.
- C The forward reaction is endothermic.
- D The concentration of B is higher at a lower temperature.

(3)

- 4.4 The most common filling for tooth cavities is 'dental amalgam' – a solid solution of tin and silver in mercury. If you bite on a piece of aluminium foil that is in contact with a dental filling in your mouth, you may feel a painful sensation because ...
- A the aluminium foil is hard.
  - B a temporary galvanic cell has been set up whilst the aluminium and fill are in contact.
  - C electrons are being transferred to the aluminium.
  - D a temporary electrolytic cell has been set up whilst the aluminium and fill are in contact. (3)
- 4.5 Eutrophication in water is caused by ...
- A algal bloom.
  - B a depletion of oxygen concentration.
  - C bacterial nitrogen fixation.
  - D an increase in plant nutrients. (3)
- TOTAL SECTION A: 35**

**SECTION B****INSTRUCTIONS**

1. Answer this section in the ANSWER BOOK.
2. In ALL calculations the formulae and substitutions must be shown.
3. Round off your answers to TWO decimal places where applicable.

**QUESTION 5**

There are two structural isomers for the organic compound with molecular formula  $C_2H_4O_2$ .

- 5.1 Define the term *structural isomer*. (2)
- 5.2 Write down the structural formula of these two isomers and next to each its IUPAC name. (3 x 2) (6)
- 5.3 State with reason which ONE of these isomers:
- 5.3.1 Has the higher boiling point (3)
- 5.3.2 Has the higher vapour pressure (3)
- 5.4 Will the vapour pressure of carboxylic acids increase or decrease if the number of carbon atoms in the chain increases? Give a reason for your answer. (3)

**[17]**

**QUESTION 6**

Rubber is a naturally occurring compound. The diene, 2-methyl-1,3-butadiene, is one of the repeating units found in rubber.

Over 20 million families depend on rubber cultivation for their livelihood. Tens of thousands of hectares of tropical forests have been cleared to make way for rubber plantations.

Chemists have been able to combine other dienes to obtain synthetic rubbers. Some rubber products include latex products such as hand gloves, raincoats and other products used in the battle against HIV/Aids.

The world's largest use of rubber is in tyres, and most tyres contain both natural rubber, which withstands heat better, and one or more kinds of synthetic rubber.

- 6.1 Is 2-methyl-1,3-butadiene an example of a saturated or an unsaturated hydrocarbon? Give a reason for your answer. (3)
- 6.2 Write down the structural formula of 2-methyl-1,3-butadiene. (2)
- 6.3 With regard to the environment, name TWO disadvantages of rubber and the production of rubber. (2)
- 6.4 With regard to human life, name TWO benefits of rubber and the production of rubber. (2)
- [9]**

**QUESTION 7**

Most organic compounds can undergo substitution or addition or elimination reactions to produce a variety of organic compounds. Some incomplete organic reactions are represented below.

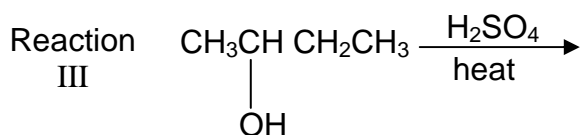
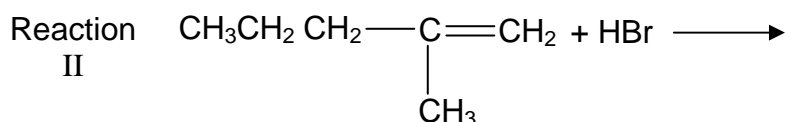
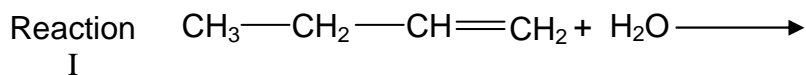

- 7.1 Name the type of reaction represented by reaction III. (1)
- 7.2 Both reactions I and II are examples of addition reactions. Name the type of addition that is represented by each reaction. (2)
- 7.3 Write down the structural formula and IUPAC name of the major product formed in reaction I. (3)
- 7.4 Reaction I only takes place in the presence of a catalyst. Write down the formula of the catalyst used in reaction I. (1)
- 7.5 Write down the structural formula and IUPAC name of the major product formed in reaction II. (3)
- 7.6 To which homologous series does the organic product formed in reaction III belong? (2)

**[12]**

**QUESTION 8**

Antacids are used to relieve indigestion. Indigestion is the condition when the stomach produces too much acid resulting in an uncomfortable and painful feeling. A certain antacid tablet dissolves in water and reacts with the acid in the stomach to release carbon dioxide gas.

8.1 Name the type of chemical reaction that explains why antacids bring relief from indigestion. (1)

8.2 A group of learners wants to investigate the effect of temperature on the rate of dissolution of this antacid tablet in water.

Design an investigation that the group of learners can conduct by answering the questions below.

8.2.1 State an investigative question. (2)

8.2.2 State a hypothesis for this investigation. (2)

8.2.3 Write down a procedure that can be followed in this investigation to test your hypothesis using some or all of the apparatus/chemicals listed below:

- Thermometer
  - Stopwatch
  - Hot plate
  - Beaker
  - Measuring cylinder
  - Spatula/Teaspoon
  - Water
  - Antacid tablet
- (4)

8.2.4 Draw a table that can be used to record the results. Indicate the relevant headings of the rows and columns in the table. No values (numerical data) are required. (4)

8.3 Is it better to take the antacid tablet with warm water or with cold water? Give a reason for your answer. (2)

**[15]**

**QUESTION 9**

Smog refers to a very unpleasant condition of pollution in certain urban environments. It is produced largely by the action of sunlight on car exhaust gases. Two groups of compounds emitted from car exhausts, that contribute to the formation of smog, are nitrogen oxides and unburned hydrocarbons.

Nitric oxide (NO(g)) forms in internal combustion engines by the direct combination of nitrogen and oxygen according to the following reversible reaction:



In air, nitric oxide is rapidly oxidised to nitrogen dioxide (NO<sub>2</sub>(g)) that initiates the reactions responsible for the formation of smog. Nitrogen dioxide acts as catalyst for the formation of ozone, a key component of smog.

Although an essential UV screen in the upper atmosphere, ozone is an undesirable pollutant in the lower atmosphere. It is extremely reactive and toxic, and breathing air containing appreciable amounts of ozone can be dangerous for asthma sufferers, sports people and the elderly.

9.1 Before the Olympic Games in Beijing, authorities were extremely concerned about the levels of smog in the city.  
Explain why high smog levels are especially dangerous for sports people. (2)

9.2 Suggest TWO ways of reducing NO(g) in urban areas. (2)

The questions below refer to the reaction in the passage above.

9.3 Explain why the formation of NO(g) is favoured in internal combustion engines where temperatures are as high as 2 400 K. (2)

9.4 During a research experiment carried out by initially adding 1 mol of O<sub>2</sub>(g) and 1 mol of N<sub>2</sub>(g) in a 2 dm<sup>3</sup> closed container at 300 K, it was found that the concentration of the NO(g) present in the container at equilibrium was 0,1 mol·dm<sup>-3</sup>.

Calculate the equilibrium constant (K<sub>c</sub>) for the reaction at this temperature. (7)

9.5 How will the amount of NO(g) at equilibrium be affected if:

9.5.1 The pressure is increased by decreasing the volume (2)

9.5.2 A catalyst is added (1)

9.6 Draw the potential energy diagram for the above reaction. Indicate the heat of reaction and the activation energy for the catalysed reaction on the diagram. (5)

**[21]**

**QUESTION 10**

The discovery of electrochemical cells has revolutionised our way of life. The diagram below represents an electrochemical cell.

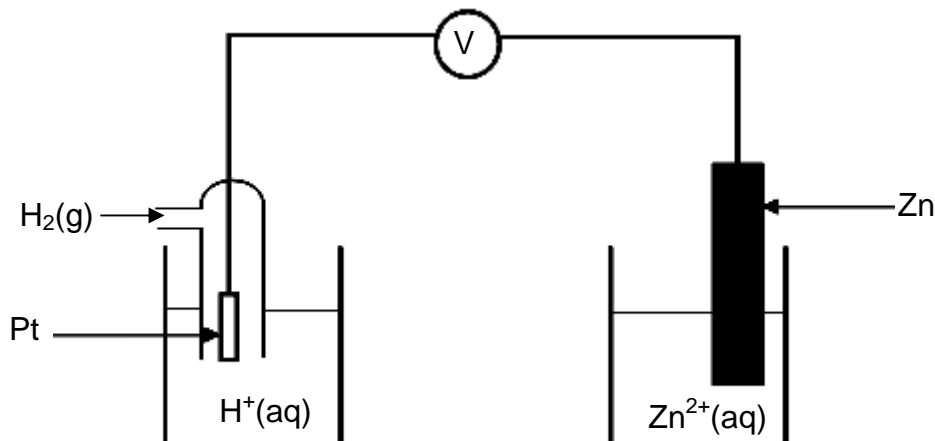

- 10.1 Name the type of electrochemical cell that converts chemical energy to electrical energy. (1)
- 10.2 If the electrochemical cell is set up as illustrated, there will be no reading on the voltmeter. Give a reason for this observation. (1)
- 10.3 Write down the value of the standard emf of the electrochemical cell when it is functioning. (1)
- 10.4 Write down the voltmeter reading when the net cell reaction in the above electrochemical cell reaches equilibrium. (1)
- 10.5 Write down the equation for the reaction that occurs at the anode. (2)
- 10.6 Another electrochemical cell is set up under standard conditions by replacing the standard hydrogen half-cell with a standard magnesium half-cell.
- 10.6.1 Which electrode will undergo a decrease in mass? Give a reason for your answer. (2)
- 10.6.2 Calculate the initial emf of this electrochemical cell at standard conditions. (4)
- 10.6.3 After a while the emf of this electrochemical cell decreases. Explain this observation by referring to the concentration of the electrolytes. (2)
- 10.7 Electrochemical cells such as motor car batteries with plastic casings can harm the environment if not disposed of safely. Suggest TWO ways how motor car batteries can be safely disposed of. (2)

**[16]**

**QUESTION 11**

An attractive silver appearance can be created by electroplating artefacts made from cheaper metals, such as nickel, with silver.

The simplified diagram below represents an arrangement that can be used to electroplate a nickel artefact with silver.

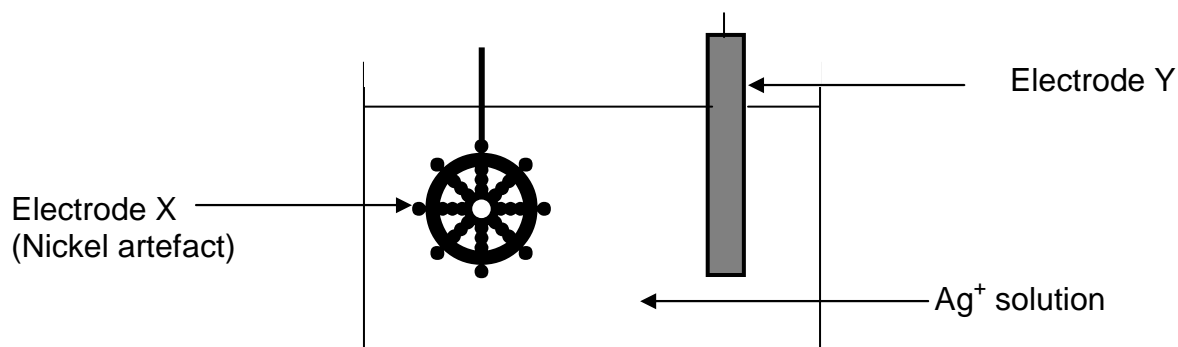

- 11.1 Which electrode (cathode/anode) will the nickel artefact represent? (1)
- 11.2 Name the metal represented by electrode Y. (1)
- 11.3 Write down the half-reaction responsible for the change that occurs at the surface of the artefact. (2)
- 11.4 Give a reason why the concentration of the electrolyte remains constant during electroplating. (2)
- 11.5 In industry some plastic articles are sometimes electroplated. Explain why plastic must be coated with graphite before electroplating. (2)
- 11.6 Give a reason why, from a business point of view, it is not advisable to plate platinum with silver. (1)

**[9]**

**QUESTION 12**

About one third of the protein consumed by humans comes from fertilisers. The flow diagram below shows three industrial processes, A, B and C, that result in the production of fertilisers.

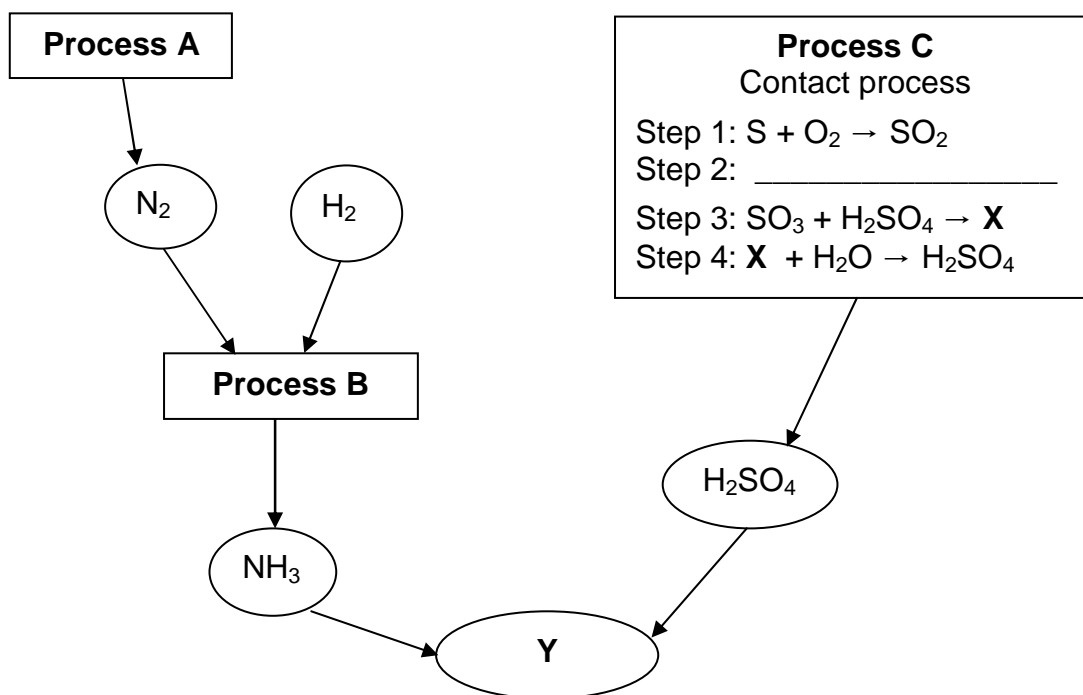

- 12.1 Write down the name of the Process A. (1)
- 12.2 Write down the balanced equation for the reaction which takes place in process B. (3)
- 12.3 Write down the balanced equation for step 2 of Process C. (3)
- 12.4 Write down the FORMULA and the NAME of product X in step 3 of Process C. (2)
- 12.5 Write the FORMULA and the NAME of the fertiliser represented by Y. (3)
- 12.6 Fertiliser prices increased by more than 200 per cent since 2007. This rise is fuelled by new demand.
- 12.6.1 Give TWO reasons why there is a continuous demand for fertilisers. (2)
- 12.6.2 Give TWO reasons why there is an increase in the price of fertilisers. (2)

**[16]****TOTAL SECTION B: 115****GRAND TOTAL: 150**

**NATIONAL SENIOR CERTIFICATE  
NASIONALE SENIOR SERTIFIKAAT**

**DATA FOR PHYSICAL SCIENCES GRADE 12  
PAPER 2 (CHEMISTRY)**

**GEGEWENS VIR FISIESE WETENSKAPPE GRAAD 12  
VRAESTEL 2 (CHEMIE)**

**TABLE 1: PHYSICAL CONSTANTS/TABEL 1: FISIESE KONSTANTES**

NAME/NAAM	SYMBOL/SIMBOOL	VALUE/WAARDE
Standard pressure <i>Standaarddruk</i>	$p^\theta$	$1,013 \times 10^5 \text{ Pa}$
Molar gas volume at STP <i>Molêre gasvolume by STD</i>	$V_m$	$22,4 \text{ dm}^3 \cdot \text{mol}^{-1}$
Standard temperature <i>Standaardtemperatuur</i>	$T^\theta$	273 K

**TABLE 2: FORMULAE/TABEL 2: FORMULES**

$n = \frac{m}{M}$	$c = \frac{n}{V}$
$c = \frac{m}{MV}$	$E_{\text{cell}}^\theta = E_{\text{cathode}}^\theta - E_{\text{anode}}^\theta / E_{\text{sel}}^\theta = E_{\text{katode}}^\theta - E_{\text{anode}}^\theta$ $E_{\text{cell}}^\theta = E_{\text{reduction}}^\theta - E_{\text{oxidation}}^\theta / E_{\text{sel}}^\theta = E_{\text{reduksie}}^\theta - E_{\text{oksidasie}}^\theta$ $E_{\text{cell}}^\theta = E_{\text{oxidising agent}}^\theta - E_{\text{reducing agent}}^\theta / E_{\text{sel}}^\theta = E_{\text{oksideermiddel}}^\theta - E_{\text{reduseermiddel}}^\theta$



NSC

**TABLE 4A: STANDARD REDUCTION POTENTIALS**  
**TABEL 4A: STANDAARD REDUKSIEPOTENSIALE**

Half-reactions/ <i>Halfreaksies</i>	$E^\theta$ (V)
$F_2(g) + 2e^- \rightleftharpoons 2F^-$	+ 2,87
$Co^{3+} + e^- \rightleftharpoons Co^{2+}$	+ 1,81
$H_2O_2 + 2H^+ + 2e^- \rightleftharpoons 2H_2O$	+1,77
$MnO_4^- + 8H^+ + 5e^- \rightleftharpoons Mn^{2+} + 4H_2O$	+ 1,51
$Cl_2(g) + 2e^- \rightleftharpoons 2Cl^-$	+ 1,36
$Cr_2O_7^{2-} + 14H^+ + 6e^- \rightleftharpoons 2Cr^{3+} + 7H_2O$	+ 1,33
$O_2(g) + 4H^+ + 4e^- \rightleftharpoons 2H_2O$	+ 1,23
$MnO_2 + 4H^+ + 2e^- \rightleftharpoons Mn^{2+} + 2H_2O$	+ 1,23
$Pt^{2+} + 2e^- \rightleftharpoons Pt$	+ 1,20
$Br_2(l) + 2e^- \rightleftharpoons 2Br^-$	+ 1,07
$NO_3^- + 4H^+ + 3e^- \rightleftharpoons NO(g) + 2H_2O$	+ 0,96
$Hg^{2+} + 2e^- \rightleftharpoons Hg(l)$	+ 0,85
$Ag^+ + e^- \rightleftharpoons Ag$	+ 0,80
$NO_3^- + 2H^+ + e^- \rightleftharpoons NO_2(g) + H_2O$	+ 0,80
$Fe^{3+} + e^- \rightleftharpoons Fe^{2+}$	+ 0,77
$O_2(g) + 2H^+ + 2e^- \rightleftharpoons H_2O_2$	+ 0,68
$I_2 + 2e^- \rightleftharpoons 2I^-$	+ 0,54
$Cu^+ + e^- \rightleftharpoons Cu$	+ 0,52
$SO_2 + 4H^+ + 4e^- \rightleftharpoons S + 2H_2O$	+ 0,45
$2H_2O + O_2 + 4e^- \rightleftharpoons 4OH^-$	+ 0,40
$Cu^{2+} + 2e^- \rightleftharpoons Cu$	+ 0,34
$SO_4^{2-} + 4H^+ + 2e^- \rightleftharpoons SO_2(g) + 2H_2O$	+ 0,17
$Cu^{2+} + e^- \rightleftharpoons Cu^+$	+ 0,16
$Sn^{4+} + 2e^- \rightleftharpoons Sn^{2+}$	+ 0,15
$S + 2H^+ + 2e^- \rightleftharpoons H_2S(g)$	+ 0,14
<b><math>2H^+ + 2e^- \rightleftharpoons H_2(g)</math></b>	<b>0,00</b>
$Fe^{3+} + 3e^- \rightleftharpoons Fe$	- 0,06
$Pb^{2+} + 2e^- \rightleftharpoons Pb$	- 0,13
$Sn^{2+} + 2e^- \rightleftharpoons Sn$	- 0,14
$Ni^{2+} + 2e^- \rightleftharpoons Ni$	- 0,27
$Co^{2+} + 2e^- \rightleftharpoons Co$	- 0,28
$Cd^{2+} + 2e^- \rightleftharpoons Cd$	- 0,40
$Cr^{3+} + e^- \rightleftharpoons Cr^{2+}$	- 0,41
$Fe^{2+} + 2e^- \rightleftharpoons Fe$	- 0,44
$Cr^{3+} + 3e^- \rightleftharpoons Cr$	- 0,74
$Zn^{2+} + 2e^- \rightleftharpoons Zn$	- 0,76
$2H_2O + 2e^- \rightleftharpoons H_2(g) + 2OH^-$	- 0,83
$Cr^{2+} + 2e^- \rightleftharpoons Cr$	- 0,91
$Mn^{2+} + 2e^- \rightleftharpoons Mn$	- 1,18
$Al^{3+} + 3e^- \rightleftharpoons Al$	- 1,66
$Mg^{2+} + 2e^- \rightleftharpoons Mg$	- 2,36
$Na^+ + e^- \rightleftharpoons Na$	- 2,71
$Ca^{2+} + 2e^- \rightleftharpoons Ca$	- 2,87
$Sr^{2+} + 2e^- \rightleftharpoons Sr$	- 2,89
$Ba^{2+} + 2e^- \rightleftharpoons Ba$	- 2,90
$Cs^+ + e^- \rightleftharpoons Cs$	- 2,92
$K^+ + e^- \rightleftharpoons K$	- 2,93
$Li^+ + e^- \rightleftharpoons Li$	- 3,05

Increasing oxidising ability/*Toenemende oksiderende vermoë*

Increasing reducing ability/*Toenemende reduserende vermoë*

NSC

TABLE 4B: STANDARD REDUCTION POTENTIALS  
 TABEL 4B: STANDAARD REDUKSIEPOTENSIALE

Half-reactions/ <i>Halfreaksies</i>	$E^\theta$ (V)
$\text{Li}^+ + e^- \rightleftharpoons \text{Li}$	-3,05
$\text{K}^+ + e^- \rightleftharpoons \text{K}$	-2,93
$\text{Cs}^+ + e^- \rightleftharpoons \text{Cs}$	-2,92
$\text{Ba}^{2+} + 2e^- \rightleftharpoons \text{Ba}$	-2,90
$\text{Sr}^{2+} + 2e^- \rightleftharpoons \text{Sr}$	-2,89
$\text{Ca}^{2+} + 2e^- \rightleftharpoons \text{Ca}$	-2,87
$\text{Na}^+ + e^- \rightleftharpoons \text{Na}$	-2,71
$\text{Mg}^{2+} + 2e^- \rightleftharpoons \text{Mg}$	-2,36
$\text{Al}^{3+} + 3e^- \rightleftharpoons \text{Al}$	-1,66
$\text{Mn}^{2+} + 2e^- \rightleftharpoons \text{Mn}$	-1,18
$\text{Cr}^{2+} + 2e^- \rightleftharpoons \text{Cr}$	-0,91
$2\text{H}_2\text{O} + 2e^- \rightleftharpoons \text{H}_2(\text{g}) + 2\text{OH}^-$	-0,83
$\text{Zn}^{2+} + 2e^- \rightleftharpoons \text{Zn}$	-0,76
$\text{Cr}^{3+} + 3e^- \rightleftharpoons \text{Cr}$	-0,74
$\text{Fe}^{2+} + 2e^- \rightleftharpoons \text{Fe}$	-0,44
$\text{Cr}^{3+} + e^- \rightleftharpoons \text{Cr}^{2+}$	-0,41
$\text{Cd}^{2+} + 2e^- \rightleftharpoons \text{Cd}$	-0,40
$\text{Co}^{2+} + 2e^- \rightleftharpoons \text{Co}$	-0,28
$\text{Ni}^{2+} + 2e^- \rightleftharpoons \text{Ni}$	-0,27
$\text{Sn}^{2+} + 2e^- \rightleftharpoons \text{Sn}$	-0,14
$\text{Pb}^{2+} + 2e^- \rightleftharpoons \text{Pb}$	-0,13
$\text{Fe}^{3+} + 3e^- \rightleftharpoons \text{Fe}$	-0,06
<b><math>2\text{H}^+ + 2e^- \rightleftharpoons \text{H}_2(\text{g})</math></b>	<b>0,00</b>
$\text{S} + 2\text{H}^+ + 2e^- \rightleftharpoons \text{H}_2\text{S}(\text{g})$	+0,14
$\text{Sn}^{4+} + 2e^- \rightleftharpoons \text{Sn}^{2+}$	+0,15
$\text{Cu}^{2+} + e^- \rightleftharpoons \text{Cu}^+$	+0,16
$\text{SO}_4^{2-} + 4\text{H}^+ + 2e^- \rightleftharpoons \text{SO}_2(\text{g}) + 2\text{H}_2\text{O}$	+0,17
$\text{Cu}^{2+} + 2e^- \rightleftharpoons \text{Cu}$	+0,34
$2\text{H}_2\text{O} + \text{O}_2 + 4e^- \rightleftharpoons 4\text{OH}^-$	+0,40
$\text{SO}_2 + 4\text{H}^+ + 4e^- \rightleftharpoons \text{S} + 2\text{H}_2\text{O}$	+0,45
$\text{Cu}^+ + e^- \rightleftharpoons \text{Cu}$	+0,52
$\text{I}_2 + 2e^- \rightleftharpoons 2\text{I}^-$	+0,54
$\text{O}_2(\text{g}) + 2\text{H}^+ + 2e^- \rightleftharpoons \text{H}_2\text{O}_2$	+0,68
$\text{Fe}^{3+} + e^- \rightleftharpoons \text{Fe}^{2+}$	+0,77
$\text{NO}_3^- + 2\text{H}^+ + e^- \rightleftharpoons \text{NO}_2(\text{g}) + \text{H}_2\text{O}$	+0,80
$\text{Ag}^+ + e^- \rightleftharpoons \text{Ag}$	+0,80
$\text{Hg}^{2+} + 2e^- \rightleftharpoons \text{Hg}(\ell)$	+0,85
$\text{NO}_3^- + 4\text{H}^+ + 3e^- \rightleftharpoons \text{NO}(\text{g}) + 2\text{H}_2\text{O}$	+0,96
$\text{Br}_2(\ell) + 2e^- \rightleftharpoons 2\text{Br}^-$	+1,07
$\text{Pt}^{2+} + 2e^- \rightleftharpoons \text{Pt}$	+1,20
$\text{MnO}_2 + 4\text{H}^+ + 2e^- \rightleftharpoons \text{Mn}^{2+} + 2\text{H}_2\text{O}$	+1,23
$\text{O}_2(\text{g}) + 4\text{H}^+ + 4e^- \rightleftharpoons 2\text{H}_2\text{O}$	+1,23
$\text{Cr}_2\text{O}_7^{2-} + 14\text{H}^+ + 6e^- \rightleftharpoons 2\text{Cr}^{3+} + 7\text{H}_2\text{O}$	+1,33
$\text{Cl}_2(\text{g}) + 2e^- \rightleftharpoons 2\text{Cl}^-$	+1,36
$\text{MnO}_4^- + 8\text{H}^+ + 5e^- \rightleftharpoons \text{Mn}^{2+} + 4\text{H}_2\text{O}$	+1,51
$\text{H}_2\text{O}_2 + 2\text{H}^+ + 2e^- \rightleftharpoons 2\text{H}_2\text{O}$	+1,77
$\text{Co}^{3+} + e^- \rightleftharpoons \text{Co}^{2+}$	+1,81
$\text{F}_2(\text{g}) + 2e^- \rightleftharpoons 2\text{F}^-$	+2,87

Increasing oxidising ability/*Toenemende oksiderende vermoë*

Increasing reducing ability/*Toenemende reduserende vermoë*

EXAMINATION NUMBER:

--

**PHYSICAL SCIENCES P2 GRADE 12 ANSWER SHEET**  
**FISIESE WETENSAPPE V2 GRAAD 12-ANTWOORDBLAD**

**QUESTION 1/VRAAG 1**

- 1.1 \_\_\_\_\_ (1)
- 1.2 \_\_\_\_\_ (1)
- 1.3 \_\_\_\_\_ (1)
- 1.4 \_\_\_\_\_ (1)
- 1.5 \_\_\_\_\_ (1)
- [5]**

**QUESTION 2/VRAAG 2**

- 2.1 \_\_\_\_\_ (1)
- 2.2 \_\_\_\_\_ (1)
- 2.3 \_\_\_\_\_ (1)
- 2.4 \_\_\_\_\_ (1)
- 2.5 \_\_\_\_\_ (1)
- [5]**

**QUESTION 3/VRAAG 3**

- 3.1 \_\_\_\_\_  
 \_\_\_\_\_ (2)
- 3.2 \_\_\_\_\_  
 \_\_\_\_\_ (2)
- 3.3 \_\_\_\_\_  
 \_\_\_\_\_ (2)
- 3.4 \_\_\_\_\_  
 \_\_\_\_\_ (2)
- 3.5 \_\_\_\_\_  
 \_\_\_\_\_ (2)
- [10]**

**QUESTION 4/VRAAG 4**

4.1	A	B	C	D
4.2	A	B	C	D
4.3	A	B	C	D
4.4	A	B	C	D
4.5	A	B	C	D

(5 x 3) [15]

**TOTAL SECTION A/TOTAAL AFDELING A: 35**