



education

Department:
Education
REPUBLIC OF SOUTH AFRICA

**NATIONAL
SENIOR CERTIFICATE**

GRADE 11

**PHYSICAL SCIENCES P1
(PHYSICS)**

EXEMPLAR 2007

MARKS: 150

TIME: 3 hours

**This question paper consists of 16 pages, a datasheet of 3 pages and
a 1-page answer sheet.**

INSTRUCTIONS AND INFORMATION

1. Write your name and/or examination number (and centre number if applicable) in the appropriate spaces on the ANSWER BOOK and on the ANSWER SHEET provided.
2. Answer ALL the questions.
3. Answer SECTION A on the attached ANSWER SHEET.
4. Answer SECTION B in the ANSWER BOOK.
5. Non-programmable calculators may be used.
6. Appropriate mathematical instruments may be used.
7. Number the answers correctly according to the numbering system used in this question paper.
8. A data sheet is attached for your use.
9. Wherever motivation, discussion, et cetera is required, be brief.

SECTION A

Answer this section on the attached ANSWER SHEET.

QUESTION 1: ONE-WORD ITEMS

Give ONE word/term for each of the following descriptions. Write only the word/term next to the question number (1.1 - 1.5) on the answer sheet:

- 1.1 The rate of change of momentum (1)
- 1.2 The class of lever in which the load lies between the fulcrum and the effort (1)
- 1.3 An insulating material filling the space between two conducting plates in a capacitor (1)
- 1.4 The lowest note produced by a musical instrument (1)
- 1.5 Substances which conduct electricity better than insulators, but not as well as conductors (1)
- [5]**

QUESTION 2: MATCHING ITEMS

Choose an item from COLUMN B that matches the description in COLUMN A. Write only the letter (A - I) next to the question number (2.1 - 2.5) on the answer sheet.

COLUMN A		COLUMN B	
2.1	The product of the mass and the velocity of an object	A	compression
2.2	Region in a sound wave where the particles are closest together	B	step-down transformer
2.3	The energy gained by an electron as it moves through a potential difference of one volt	C	electron volt
2.4	A cell phone charger	D	momentum
2.5	The unit of capacitance	E	rarefaction
		F	electrical potential energy
		G	step-up transformer
		H	net force
		I	farad

[5]

QUESTION 3: TRUE OR FALSE

Indicate whether the following statements are TRUE or FALSE. Write only 'true' or 'false' next to the question number (3.1 - 3.5) on the answer sheet. If the statement is FALSE, write down the correct statement.

- 3.1 A construction worker exerts a force on a wheelbarrow. The wheelbarrow exerts an equal but opposite force on the worker. The wheelbarrow does not move because these two forces cancel each other.

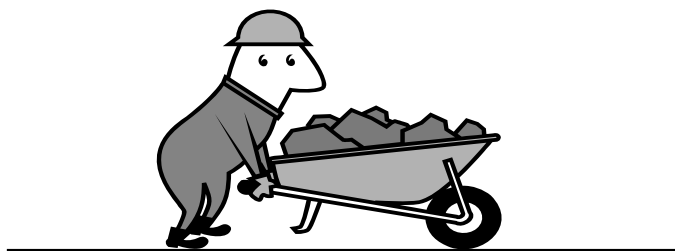

- 3.2 A high-pitched note has a high frequency. (2)
- 3.3 The iris of the eye functions like the aperture of a camera. (2)
- 3.4 The capacitance of a parallel plate capacitor of a given area and dielectric, increases with increasing distance between the plates. (2)
- 3.5 Electrical energy is transported from power stations at high voltage and high current. (2)

[10]

QUESTION 4: MULTIPLE-CHOICE QUESTIONS

Four possible options are provided as answers to the following questions. Each question has only ONE correct answer. Choose the correct answer and mark the appropriate block (A - D) next to the question number (4.1 - 4.5) on the answer sheet with a cross (X).

- 4.1 In an investigation of the relationship between acceleration (a) and force (F) for two objects (P and Q) moving on a frictionless surface, the following graph was obtained:

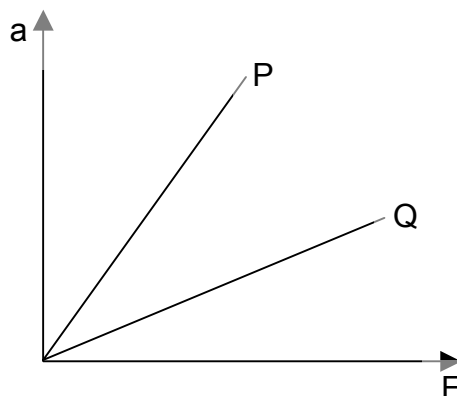

Which ONE of the following statements is TRUE?

- A Object Q has a smaller mass than object P.
- B Object Q has a bigger mass than object P.
- C The gradient of the graph is not affected by the mass of the objects.
- D Objects P and Q have equal mass.

(3)

- 4.2 A 20 kg iron ball and a 10 kg copper ball are placed a distance apart on a frictionless horizontal surface. Which ONE of the following diagrams CORRECTLY represents the magnitude, in terms of F , and the direction of the gravitational force that the iron ball and the copper ball exert on each other?

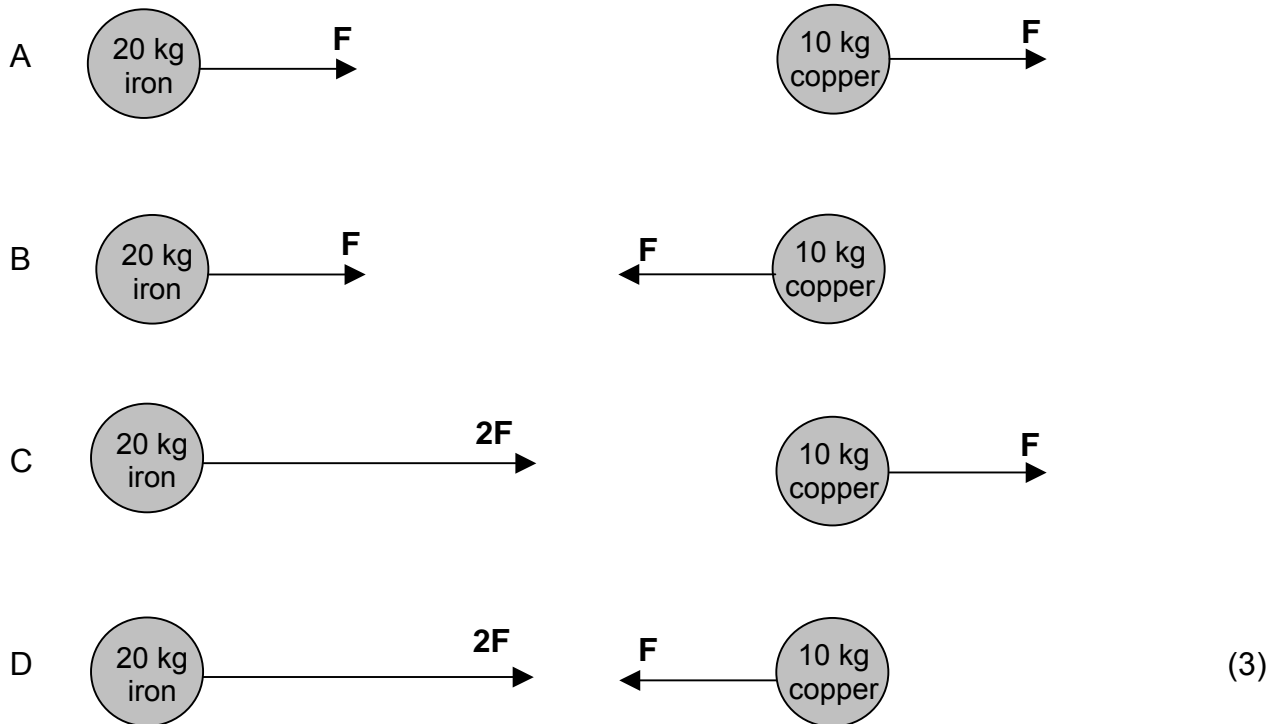

- 4.3 In pure silicon there are equal numbers of free electrons and holes. It is also known that the free electrons move three times faster than the holes. The free electrons would therefore carry ... of the current.

- A 100%
- B 75%
- C 50%
- D 25%
- (3)

- 4.4 Two spheres, S and T, on insulated stands, carry charges Q and q respectively and their centres are a distance r apart.

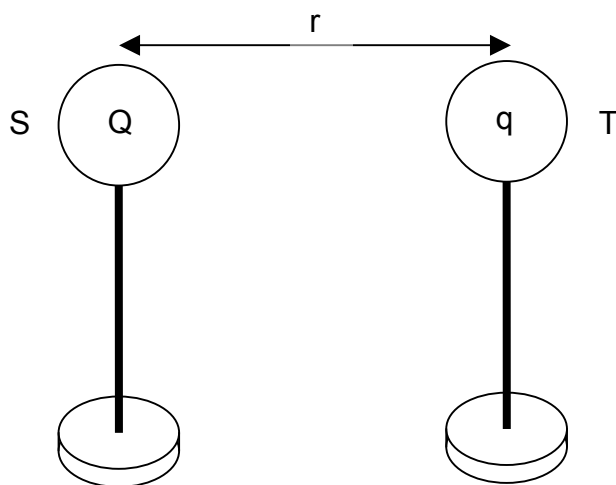

Which ONE of the following formulae could be used to calculate the magnitude of the electric field strength at the position of sphere S?

A $E = \frac{W}{qr}$

B $E = \frac{F}{q}$

C $E = \frac{kQ}{r^2}$

D $E = \frac{kq}{r^2}$

(3)

- 4.5 In the circuit diagram represented below, three identical resistors are connected as shown. The battery, ammeter A and connecting wires have negligible resistance. The switch S in the circuit is open.

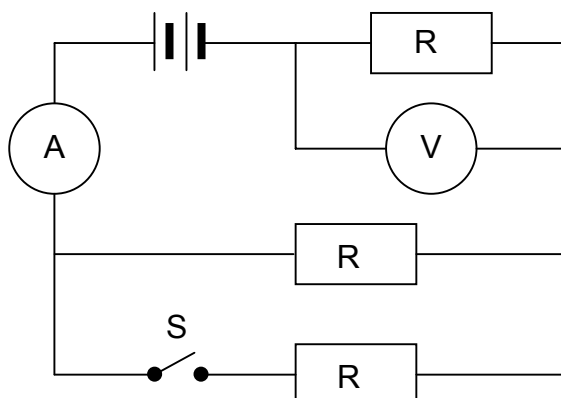

Switch S is now closed. Which ONE of the following combinations CORRECTLY gives the readings on the ammeter and voltmeter?

	Ammeter reading	Voltmeter reading
A	increases	increases
B	increases	decreases
C	decreases	increases
D	decreases	decreases

(3)
[15]

TOTAL SECTION A: 35

SECTION B**INSTRUCTIONS**

1. Answer this section in the ANSWER BOOK.
2. In ALL calculations, formulae and substitution must be shown.
3. Round off your answers to TWO decimal places.

QUESTION 5

A lady injured her back when she slipped and fell in a supermarket. She holds the owner of the supermarket accountable for her medical expenses. The owner claims that the floor covering was not wet and meets the accepted standards. He therefore cannot accept responsibility.



The matter eventually ends up in court. Before passing judgement, the judge approaches you, a science student, to determine whether the coefficient of static friction of the floor is a minimum of 0,5 as required. He provides you with a tile from the floor, as well as one of the shoes the lady was wearing on the day of the incident.

- 5.1 Write down an expression for the coefficient of static friction. (2)
- 5.2 Plan an investigation that you will perform to assist the judge in his judgement. Follow the steps outlined below to ensure that your plan meets the requirements:
- 5.2.1 Formulate an investigative question. (2)
- 5.2.2 Apparatus: List ALL the other apparatus, except the tile and the shoe, that you will need. (2)
- 5.2.3 A stepwise method: How will you perform the investigation? Include a relevant, labelled free body-diagram. (5)
- 5.2.4 Results: What will you record? (2)
- 5.2.5 Conclusion: How will you interpret the results to draw a conclusion? (2)

[15]

QUESTION 6

An athlete is preparing for a fitness competition. In order to develop the biceps muscle, she embarks on a training programme. This programme entails holding a 176 N weight steady in the palm for some minutes at a time.

The forearm weighs 24 N. It is held horizontally as shown in the sketch, and can be regarded as a rod. In the diagram below, the elbow joint is the pivot. The weight of the forearm acts through the point C. The maximum force developed in the biceps muscle, due to the weight, is represented by F_M .

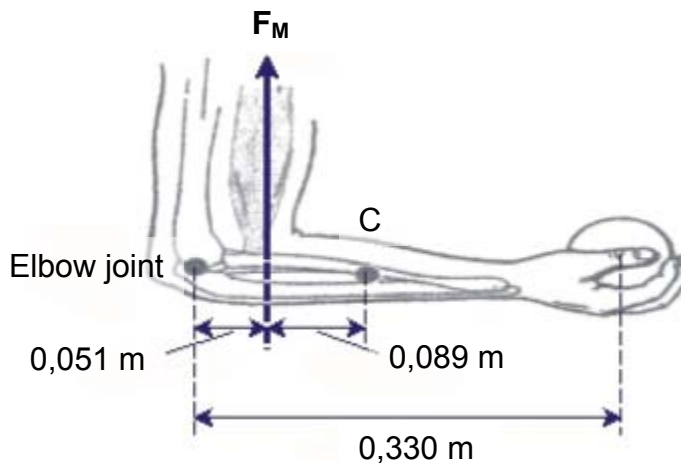

- 6.1 What do you understand by the term *torque*? (2)
- 6.2 Represent the forearm as a bar and indicate ALL the forces acting on the forearm. HINT: Assume that the elbow joint exerts a downward force, F_E . (2)
- 6.3 Calculate the force F_M developed in the biceps muscle and the force F_E exerted by the elbow joint. Assume the force F_E acts downwards. (6)
- 6.4 Is the direction assigned to the force on the elbow joint correct? Give a reason for your answer. (2)

Arthritis is a medical condition which affects many South Africans. In simple terms, it is a condition in which the joints (such as the elbow joint), become swollen. A patient complains that lifting even the smallest object causes much pain.

- 6.5 Explain why a patient with arthritis should not lift heavy objects. (2)

[14]

QUESTION 7**Visit your optometrist regularly**

Optometrists deal with vision problems. They examine the eyes and prescribe spectacles when vision becomes defective.

A father, a child and the child's grandmother visit an optometrist together. The father works in a factory where they make microchips. He complains that he has perfect eyesight for his work, which includes assembling tiny components, but has difficulty seeing while driving to work.

The child complains that he has difficulty reading his textbooks, but can read very easily from the board in the classroom.

The grandmother complains that she has no problem in observing monkeys playing on the farm next to her house, but whenever she tries to read her favourite magazine, her eyes always water. There is also a sharp pain in her eyes, which disappears whenever she moves the magazine further away from her face.

Assume that you are the optometrist.

- 7.1 State the eye defect that EACH of the three family members has. (3)
- 7.2 Describe the possible cause(s) of EACH of the defects. (6)
- 7.3 Make separate sketches to indicate the following:
- 7.3.1 The defect in the case of the father. (2)
- 7.3.2 How the defect in QUESTION 7.3.1 can be corrected using an appropriate lens. (3)

[14]

QUESTION 8

Read the following passage on noise pollution and answer the questions that follow.

Noise pollution in the community

Unpleasant or unwanted sounds are called noise. It interferes with speech communication and can be annoying during relaxation and leisure time. Noise is known to damage the ears, cause tiredness and loss of concentration and, if it is very loud, it can result in sickness.

The lowest sound level the average human ear can just detect, called the threshold of hearing is taken as 0 dB. Normal conversation is about 60 dB and the threshold of pain is 120 dB.

The main sources of noise pollution in communities are transport services, such as aircraft arrivals and departures, road traffic and railways, industrial and commercial centres, construction activities and (increasingly) leisure activities. Noise from neighbours (stereo systems, late-night parties, children and barking dogs) is now the cause of many complaints in communities.

Some of the ways of reducing unwanted sounds include, amongst others, the design of quieter engines for use in vehicles on our roads; the use of sound-insulating materials such as carpets and curtains, and double-glazed windows in our homes. The further away the noise originates, the weaker it is. Distance is thus a natural barrier, as are trees between houses on a noisy road.

- 8.1 In what unit is loudness measured? (1)
- 8.2 Suggest TWO ways to your local municipality how they can help reduce the noise levels in your area. (2)
- 8.3 State TWO precautions which factory owners can take to protect their workers against unwanted sounds. (2)

The following pattern of a sound wave associated with human speech at 60 dB, has a frequency of 500 Hz:

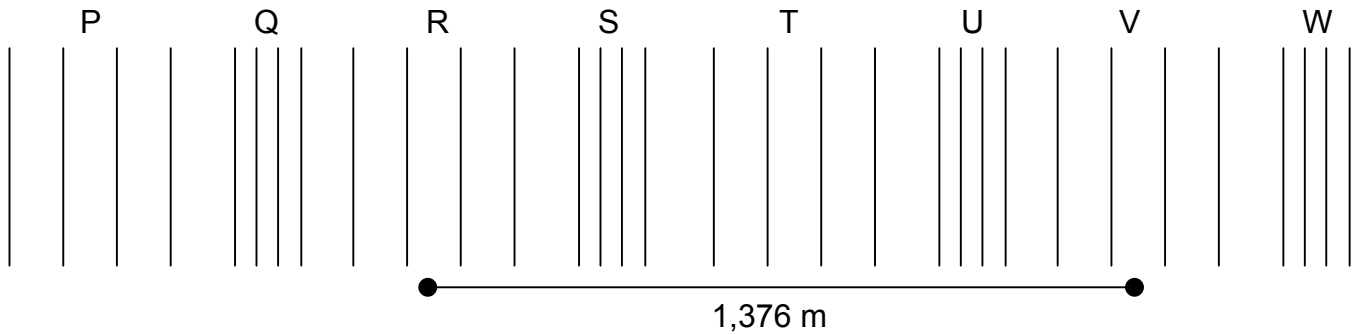

- 8.4 Draw the corresponding particle position versus time graph of the wave shown above. Indicate ALL the corresponding points on the graph. (4)
- 8.5 Write down the letters of TWO consecutive points on the wave, which are in phase. (2)
- 8.6 Calculate the period of this wave. (3)
- 8.7 Calculate the speed of this wave. (4)
- [18]**

QUESTION 9

Bats are nearly blind. To avoid flying into objects and to help them hunt for food, bats send out high frequency squeaks. Bats sense the time that the echo takes to return to them after the wave has been reflected from an object in its path. When a bat approaches an object, it emits squeaks of a shorter duration and with shorter intervals between squeaks.

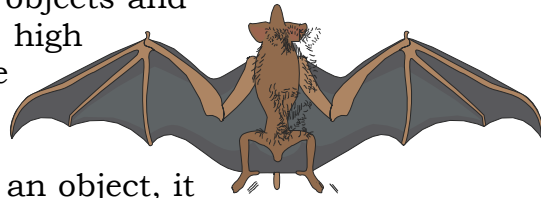

A stationary bat emits a squeak. It takes 0,018 s for the echo to return to the bat. The speed of sound in air is $345 \text{ m}\cdot\text{s}^{-1}$.

- 9.1 Calculate how far the bat is from the obstacle. (5)

Sound waves are disturbed by objects that are comparable to, or larger than, their wavelength. The maximum frequency that bats can emit, is $1,2 \times 10^5 \text{ Hz}$.

- 9.2 Calculate the diameter (in mm) of the smallest object that a bat can detect. (4)

[9]

QUESTION 10

Silicon and germanium are elements in group 4 in the Periodic Table. Silicon, germanium and gallium arsenide are typical semi-conductors that have the same crystal structure as diamond.

- 10.1 How many valence electrons does germanium have? (2)
- 10.2 What is the shape of the unit crystal that is formed when one germanium atom is bonded to FOUR other germanium atoms? (2)

The following illustrations represent the band structure of silicon and germanium:

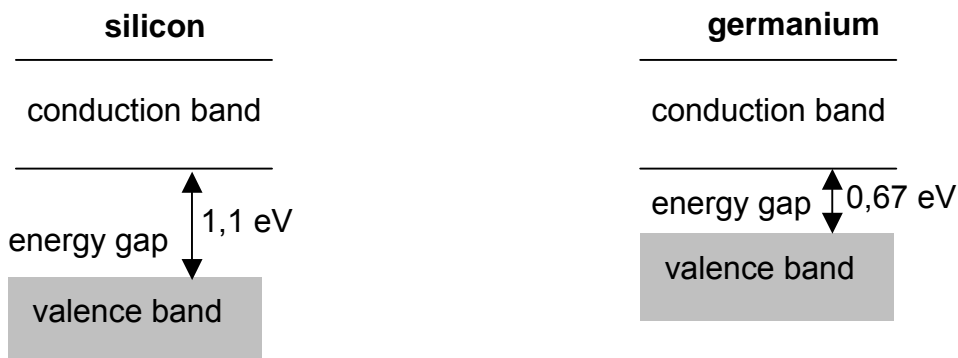

- 10.3 How does the band theory of conduction explain the difference in conductivity between semi-conductors and metals? (2)
- 10.4 From the information provided in the illustrations above, what can you deduce about the conduction ability of both silicon and germanium? (2)
- 10.5 Explain why silicon is the preferred choice as semi-conductor in electronic devices. (2)

[10]

QUESTION 11

A learner suspends a graphite-coated polystyrene sphere T from the ceiling by means of a very light inelastic thread. The sphere carries a charge of $+4,8 \times 10^{-8} \text{ C}$ and has a mass of 2 g. The learner now brings an insulated stand, on which an identically charged sphere S is mounted, close to sphere T. Sphere T settles in an equilibrium position so that the centres of the spheres are 5 cm apart, as indicated in the diagram.

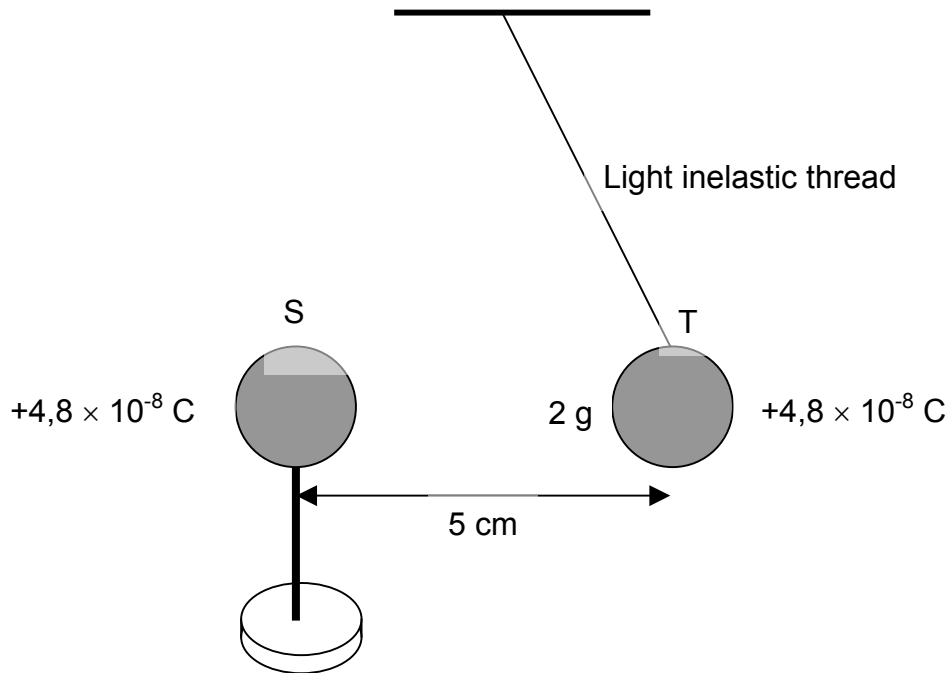

- 11.1 Briefly explain why the polystyrene spheres need to be coated with graphite. (2)
- 11.2 Calculate the **magnitude and direction** of the electrostatic force that sphere S exerts on sphere T. (6)
- 11.3 Draw a dot to represent sphere T. Draw and label ALL the forces acting on the sphere. Write down the magnitudes of TWO of the forces. (5)

[13]

QUESTION 12

Michael Faraday, a self-educated English physicist and chemist discovered that when the magnetic field through a loop is changing, a current is induced in the loop. This discovery led to the development of the electricity supply industry.

12.1 State, in words, **Faraday's law**. (2)

One complete wire loop has an area of $0,1 \text{ m}^2$ and resistance of 10Ω . The magnetic field perpendicular to the plane of the loop initially has a magnitude of $0,2 \text{ T}$ and is reduced to zero uniformly in a time of 10^{-4} s .

Calculate the following:

12.2 Induced emf (8)

12.3 Resulting induced current (4)

[14]

QUESTION 13

The simplified circuit diagram represented below shows part of the electric wiring of a model dolls' house. Bulb B and a fan F are connected to a 12 V car battery. The internal resistance of the car battery cannot be ignored.

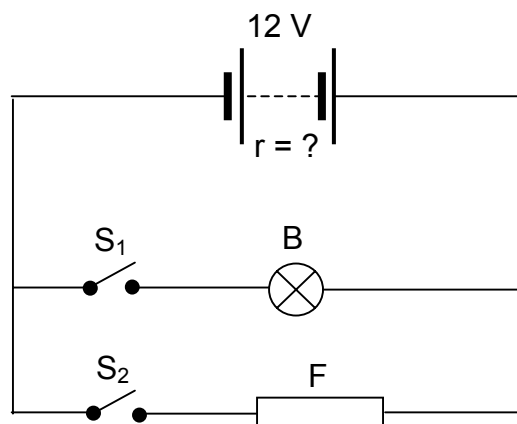

13.1 The bulb is rated 12 V; 15 W. When switch S_1 is closed, at maximum voltage, the bulb allows a maximum current of 1,25 A to pass through it. Calculate the resistance of the bulb filament. (4)

13.2 With switches S_1 and S_2 closed, the bulb glows a little dimmer. Fully explain why the bulb glows dimmer. (4)

[8]

TOTAL SECTION B: 115

GRAND TOTAL: 150

**NATIONAL SENIOR CERTIFICATE EXAMINATION
NASIONALE SENIORSERTIFIKAAT-EKSAMEN**

**DATA FOR PHYSICAL SCIENCES GRADE 11
PAPER 1 (PHYSICS)**

**GEGEWENS VIR FISIESE WETENSKAPPE GRAAD 11
VRAESTEL 1 (FISIKA)**

TABLE 1: PHYSICAL CONSTANTS/TABEL 1: FISIESE KONSTANTES

NAME/NAAM	SYMBOL/SIMBOOL	VALUE/WAARDE
Acceleration due to gravity <i>Swaartekragversnelling</i>	g	9,8 m·s ⁻²
Speed of light in a vacuum <i>Spoed van lig in 'n vakuum</i>	c	3,0 x 10 ⁸ m·s ⁻¹
Gravitational constant <i>Swaartekragkonstante</i>	G	6,67 x 10 ⁻¹¹ N·m ² ·kg ⁻²
Coulomb's constant <i>Coulomb se konstante</i>	k	9,0 x 10 ⁹ N·m ² ·C ⁻²
Charge on electron <i>Lading op elektron</i>	e ⁻	-1,6 x 10 ⁻¹⁹ C
Electron mass <i>Elektronmassa</i>	m _e	9,11 x 10 ⁻³¹ kg
Permittivity of free space <i>Permittiwiteit van 'n vakuum</i>	ε ₀	8,85 x 10 ⁻¹² F·m ⁻¹

TABLE 2: FORMULAE/TABEL 2: FORMULES**MOTION/BEWEGING**

$v_f = v_i + a \Delta t$	$\Delta x = v_i \Delta t + \frac{1}{2} a \Delta t^2$
$v_f^2 = v_i^2 + 2a \Delta x$	$\Delta x = \left(\frac{v_f + v_i}{2} \right) \Delta t$

FORCE/KRAG

$F_{\text{net}} = ma$	$p = mv$
$F = \frac{Gm_1 m_2}{r^2}$	$F \Delta t = \Delta p = mv - mu$
$\mu_s = \frac{f_{s(\text{max})}}{N}$	$\mu_k = \frac{f_k}{N}$

WEIGHT AND MECHANICAL ENERGY/GEWIG EN MEGANIESE ENERGIE

$F_g = mg$	$U = E_p = mgh$
$K = E_k = \frac{1}{2} mv^2$	

WAVES, LIGHT AND SOUND/GOLWE, LIG EN KLANK

$v = f \lambda$ or $v = v \lambda$	$T = \frac{1}{f}$ or $T = \frac{1}{v}$
------------------------------------	--

ELECTROSTATICS/ELEKTROSTATIKA

$F = \frac{kQ_1 Q_2}{r^2}$ (k = 9,0 x 10 ⁹ N·m ² ·C ⁻²)	$E = \frac{F}{q}$
$E = \frac{kQ}{r^2}$ (k = 9,0 x 10 ⁹ N·m ² ·C ⁻²)	$E = \frac{V}{d}$
$V = \frac{W}{Q}$	$W = QEs$
$U = \frac{kQ_1 Q_2}{r}$ (k = 9,0 x 10 ⁹ N·m ² ·C ⁻²)	$C = \frac{Q}{V}$
$C = \frac{\epsilon_0 A}{d}$	

TABLE 2: FORMULAE/TABEL 2: FORMULES**ELECTROMAGNETISM/ELEKTROMAGNETISME**

$\varepsilon = -N \frac{\Delta\Phi}{\Delta t}$	$\Phi = BA$
$\frac{V_s}{V_p} = \frac{N_s}{N_p}$	$F = qvB$

CURRENT ELECTRICITY/STROOMELEKTRISITEIT

$I = \frac{Q}{\Delta t}$	$R = \frac{V}{I}$
$\text{emf / emk} = I(R + r)$	$R = r_1 + r_2 + r_3 + \dots$
$\frac{1}{R} = \frac{1}{r_1} + \frac{1}{r_2} + \frac{1}{r_3} + \dots$	

NAME/EXAMINATION NUMBER:

PHYSICAL SCIENCES GRADE 11 ANSWER SHEET
FISIESE WETENSKAPPE GRAAD 11 ANTWOORDBLAD

QUESTION 1/VRAAG 1

1.1 _____ (1)

1.2 _____ (1)

1.3 _____ (1)

1.4 _____ (1)

1.5 _____ (1)

[5]**QUESTION 2/VRAAG 2**

2.1 _____ (1)

2.2 _____ (1)

2.3 _____ (1)

2.4 _____ (1)

2.5 _____ (1)

[5]**QUESTION 3/VRAAG 3**

3.1 _____ (2)

3.2 _____ (2)

3.3 _____ (2)

3.4 _____ (2)

3.5 _____ (2)

[10]**QUESTION 4/VRAAG 4**

4.1	A	B	C	D
4.2	A	B	C	D
4.3	A	B	C	D
4.4	A	B	C	D
4.5	A	B	C	D

(5 x 3) [15]**TOTAL SECTION A/TOTAAL AFDELING A: 35**